

Product

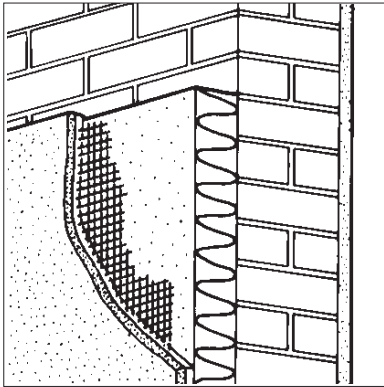

• THIS DETAIL SHEET RELATES TO THE ALSECCO AWK2 EXTERNAL WALL INSULATION SYSTEM, A SYSTEM EMPLOYING EXPANDED POLYSTYRENE INSULATION BOARDS AND GLASS-FIBRE REINFORCING MESH WITH RENDER FINISHES.

- The system is applied to the outside of external walls of masonry or dense concrete construction and is suitable for new or existing buildings.
- It is essential that the AWK2 system is installed and maintained in accordance with the conditions set out in the Design Data and Installation parts of this Certificate.
- See the Appendix for system summary.

This Detail Sheet must be read in conjunction with the Front Sheets, which give the system's position regarding the Building Regulations, general information relating to the product, and the Conditions of Certification.

Technical Specification

1 Description

1.1 The Alsecco AWK2 External Wall Insulation System (see Figure 1) comprises:

- (1) Thermastick MK and MP — cement based ready mixed adhesives supplied as a powder to which clean water is added. Comprises limestone sand conforming to BS 1199 and 1200 : 1976, cement to BS 12 : 1991 and additives.
- (2) Expanded polystyrene insulation boards — 1200 mm by 600 mm in a range of thicknesses from 10 mm to 200 mm, with a nominal density of 15 kgm^{-3} and a minimum compressive strength of 70 kNm^{-2} . Boards are manufactured to comply with the requirements for Grade SD (standard duty), type FRA (flame retardant additive) material to BS 3837 : Part 1 : 1986.
- (3) Alsecco Glass-fibre Mesh 32 — a one metre wide mesh of multi-stranded alkali-resistant glass fibres, having a polymer coating and a nominal weight of 160 gm^{-2} .
- (4) Basecoat L — a cement based ready mixed basecoat supplied as a powder to which clean water is added. Comprises limestone sand conforming to BS 1199 and 1200 : 1976, cement to BS 12 : 1991 and additives.
- (5) Top Primer P — an acrylic resin based emulsion containing fine fillers, pigment and coalescing agent used as a bonding agent and pre-coat to control suction.
- (6) Top Primer Si — a silicate/acrylic resin based emulsion containing fine fillers, pigment and coalescing agent used as a bonding agent and pre-coat to control suction.
- (7) Top Primer Sc — a silicon resin based emulsion containing fine fillers, pigment and coalescing agent used as a bonding agent and pre-coat to control suction.
- (8) Miratect R — a pre-coloured polymer modified cement based ready mixed render supplied as a powder to which clean water is added. Comprises limestone sand conforming to BS 1199 and 1200 : 1976, cement to BS 12 : 1991 and polymers.
- (9) Miratect T — a pre-coloured polymer modified cement based ready mixed render supplied as a powder to which clean water is added. Comprises limestone sand conforming to BS 1199 and 1200 : 1976, cement to BS 12 : 1991 and polymers.
- (10) Alsitect T — a pre-coloured ready mixed, silicate based, textured coating.
- (11) Alsitect R — a pre-coloured ready mixed, silicate based, textured coating.
- (12) Silitect T — a pre-coloured ready mixed, silicone based, textured coating.
- (13) Silitect R — a pre-coloured ready mixed, silicone based, textured coating.
- (14) Ancillary materials:
Alsecco profiles comprising aluminium base profile, aluminium or stainless steel edge profile,

aluminium, stainless steel or galvanized corner profile with optional PVC-U nosing, aluminium, galvanized or stainless steel render stop profile, aluminium movement joint and aluminium or PVC-U expansion joint.

Alsecco profile fixings as approved by the BBA and Alsecco (U.K.) Ltd.

Alsecco mechanical fixing comprising a polyethylene ribbed fixing with a stainless steel, galvanized steel, polypropylene or nylon central pin used as supplementary fixings. Mechanical fixings are approved by the BBA and Alsecco (U.K.) Ltd.

Alsecco heavy duty mesh comprising a one metre wide mesh of multi-stranded alkali-resistant glass fibres, having a polymer coating and a nominal weight of 330 gm^{-2} .

Alsecco sealing tape comprising precompressed expanding polyurethane foam tape.

Alsecco joint sealant comprising an acrylic based sealant.

1.2 EPS insulation boards are fixed to the external surface of the wall using the Thermastick MK or MP adhesive (see Figure 2). The insulation boards are protected by a basecoat containing a glass-fibre reinforcement mesh. After allowing the basecoat to dry, a top coat is applied to the required thickness.

1.3 All components are subject to routine in-factory quality control.

Figure 1 The Alsecco AWK2 External Wall Insulation System

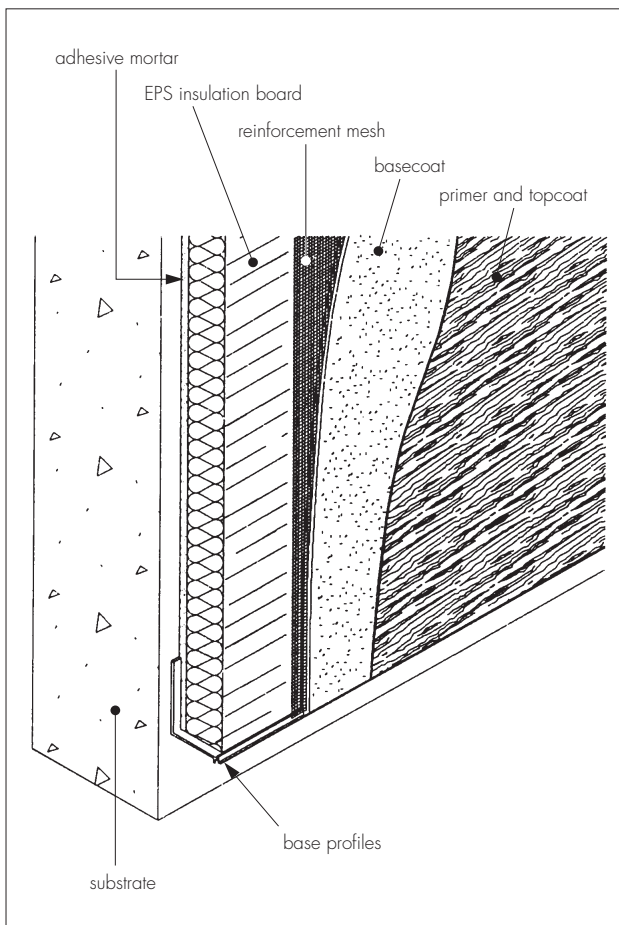
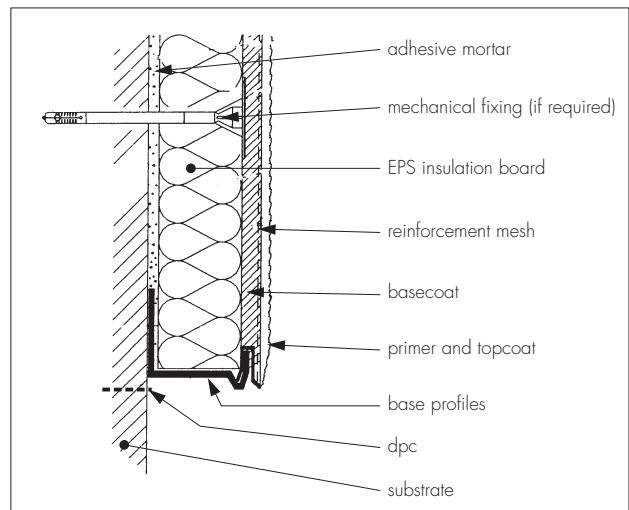

Figure 2 Typical section at base level



2 Delivery and site storage

2.1 The insulation is delivered to site wrapped in polythene. Each pack carries the product identification and batch numbers.

2.2 Components are delivered to site in the bags and quantities as listed in Table 1. Each bag carries the product identification, manufacturer's batch number and the BBA identification mark incorporating the number of this Certificate.

2.3 The insulation should be stored on a firm, clean, level base, off the ground and under cover until required for use. Care must be taken when handling the insulation to avoid damage.

2.4 The insulation boards must be protected from prolonged exposure to sunlight either by storing opened packs under cover or re-covering with opaque polythene sheeting. Care must be taken to avoid contact with solvents or materials containing volatile organic components such as coal tar, pitch, timber newly treated with creosote, etc. The boards must not be exposed to open flame or other ignition sources.

2.5 The powder adhesives, basecoat and topcoats must be stored in dry conditions, off the ground, and should be protected from frost at all times.

2.6 The paste basecoat and topcoats must be stored in a safe area, under cover, and protected from excessive heat and frost at all times.

Table 1 Component supply details

Component	Quantity and packaging
Adhesives and Basecoat	25 kg paper bag
Alsecco Glass-fibre Mesh 32	1 metre wide rolls, 50 metre length
Alsecco Heavy Duty Mesh	1 metre wide rolls, 25 metre length
Primer	10 or 15 litre plastic drum
Basecoats/topcoats	25 kg polyethylene bag, drum or paper bag

3 Strength and stability

3.1 The Alsecco AWK2 External Wall Insulation System has adequate resistance to impact and abrasion where walls are exposed and have some protection, eg walls of private dwellings and walls of communal dwellings above ground-floor level. Where the system may be exposed to severe mechanical or malicious impact, eg walls of public buildings at ground-floor level, appropriate design measures, eg supplementary reinforcement, introduction of planting areas to restrict access, etc, should be considered to reduce the risk of damage. Guidance may be obtained from the Certificate holder and BRE Current Paper CP 6 : 81 *Assessment of external walls — Hard Body Impact Resistance*.

3.2 The system as specified in this Detail Sheet can be designed to withstand the thermal stresses and wind pressures (including suction) normally experienced in the United Kingdom. The system can also be designed in accordance with CP 3 : Chapter V : Part 2 : 1972 or BS 6399 : Part 2 : 1995 to withstand the increased wind loads associated with tall buildings (greater than 12 metres) and areas of high exposure. This may require the use of additional mechanical fixings.

4 Properties in relation to fire

 4.1 The system would not be classified non-combustible when tested in accordance with BS 476 : Part 4 : 1970(1984). However, as the system is classified Class 0 (see section 4.2), in the opinion of the BBA the use of the system will not introduce any additional hazard in respect of behaviour in fire when compared with a system using traditional sand/cement render finishes.

4.2 The system is classified Class 0 as described in the national Building Regulations:

England and Wales

Approved Document B, paragraph A12.

Scotland

Technical Standards, Part D, Appendix.s

Northern Ireland

Technical Booklet E, paragraph 2.4.

4.3 The behaviour in fire of external wall insulation systems is the subject of recommendations by the Building Research Establishment which, for this system, makes no restriction on the height of building to be treated provided fire barriers are included at every floor level from the third storey.

5 Proximity of flues

 When a system is installed in close proximity to certain flue pipes the relevant provisions of the national Building Regulations should be met:

England and Wales

Approved Document J.

Scotland

Technical Standards, Part F.

Northern Ireland

Technical Booklet L.

6 Thermal insulation

6.1 For the purpose of U value calculations to determine if the requirements of the Building (or other statutory) Regulations are met, the thermal conductivity (λ values) of the insulation may be taken as $0.037 \text{ Wm}^{-1}\text{K}^{-1}$.

 6.2 The requirement for limiting the heat loss through the building fabric will be satisfied if the U values of the building elements do not exceed the maximum values in the relevant Elemental Approach given in the national Building Regulations:

England and Wales

Approved Document L2. The effect of thermal bridges should be taken into account.

Scotland

Technical Standards, Part J.

Northern Ireland

Technical Booklet F.

6.3 Guidance is also given in these documents on selecting the thickness of insulation required to enable a wall to achieve the desired U value. Alternative approaches are also described which allow for some flexibility in design of U values for individual constructional elements.

6.4 Where insulation boards have not been continued into window or door reveals due to a lack of clearance there will be a risk of cold bridging at these points. Where door and window frames are to be replaced it is recommended that their size be adjusted to permit the reveals to be insulated.

6.5 Depending on constructional details, cold bridging can also occur at the eaves and at ground-floor level, and care should be taken to minimise this, eg roof or loft insulation should continue over the wall head, ensuring that ventilation openings are not obstructed.

7 Durability

 7.1 The results of accelerated ageing tests in accordance with MOAT No 22 : 1988 indicate that the system is durable. The system should remain effective for at least 30 years, provided any damage to the surface finish is

repaired immediately, and regular maintenance is undertaken including checks on joints in the system and on external plumbing fittings to identify leakage of rainwater into the system, enabling steps to be taken to correct the defects.

7.2 The finishes may become soiled in time, the rate depending on the locality. The appearance can be restored by a powerwash at 30 bar maximum pressure and 30°C maximum temperature or, if required, by the application of a further finish of paint, but great care must be taken not to adversely affect the water vapour transmission characteristics of the systems.

Installation

8 Procedure

General

8.1 Application is carried out in accordance with Alsecco (U.K.) Ltd's current installation instructions.

8.2 Application of coating materials must not be carried out at temperatures below 5°C or above 30°C, nor if exposure to frost is likely, and the coating must be protected from rapid drying. Weather conditions should therefore be monitored to ensure correct curing conditions.

8.3 All rendering should be in accordance with the relevant recommendations of BS 5262 : 1991.

Positioning and securing insulation boards

8.4 The base profile is secured to the external wall above the damp-proof course using the approved profile fixings at approximately 500 mm centres (see Figure 2). Base rail connectors are inserted at all rail joints.

8.5 Thermastick MK or MP is prepared by mixing each bag with 4.5 litres or 5.5 litres of water, respectively. The adhesive is applied in a continuous line around the perimeter of the board with six additional dabs of adhesive distributed uniformly over the remaining surface and should cover at least 50% of the board. Alternatively, the adhesive can be applied over the entire face of the insulation board using a notched trowel.

8.6 The boards must be pressed firmly against the wall and butted tightly together with the vertical joints staggered by at least 200 mm (see Figure 3). Joints between boards which are greater than 2 mm should be filled with slivers of insulation board or Alsecco PU foam. Gaps greater than 10 mm should be closed by repositioning or, where appropriate, cutting boards to fit. Any gaps, high spots or irregularities are removed by lightly planing with a rasp over the whole surface.

Figure 3 Arrangement of insulation boards

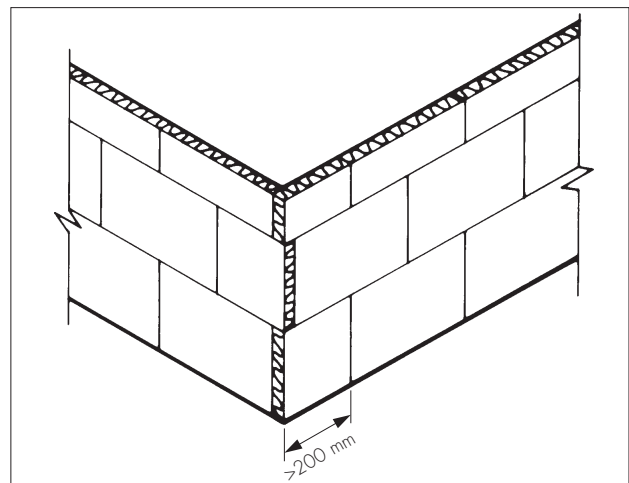

8.7 To fit around details such as doors and windows, the boards may be cut with a sharp knife or a fine-tooth saw. If required, purpose-made window sills are fitted. They are designed to prevent water ingress and incorporate drips to shed water clear of the system.

8.8 Installation continues until the whole wall is completely covered including, where appropriate, the building soffits.

8.9 The adhesive must be allowed to set prior to rendering, mechanical fixing or any finishing work. The drying time will depend on weather conditions, but a minimum of 24 hours should be allowed.

8.10 Prior to the reinforcement coat, pre-compressed sealing tape is inserted at window and door frames, overhanging eaves, gas and electric meter boxes, wall vents, or where the render abuts any other building material or surface.

8.11 Angle beads are fixed to all building corners and to door and window heads and jambs using the basecoat render.

Movement joints

8.12 Generally, movement joints are not required in the system but, if an expansion joint is incorporated in the substrate, a movement joint must be provided in the insulation system (see Figure 4).

Figure 4 Vertical movement joint

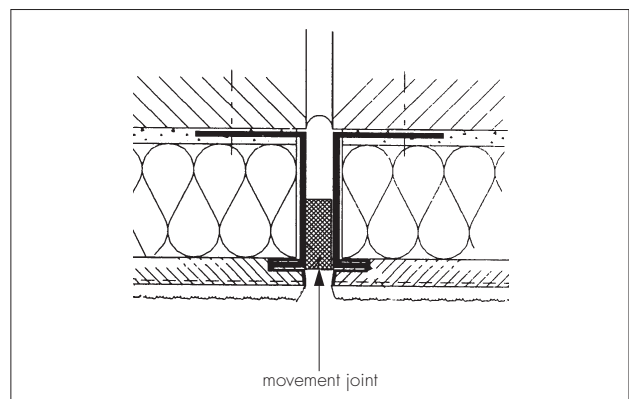

Reinforcing

8.13 Basecoat L is prepared by mixing each bag with 9 litres to 10 litres of water and is applied to a thickness of approximately 5 mm over the insulation boards, using a stainless steel trowel. The basecoat is applied progressively, working in one metre sections in a vertical or horizontal direction.

8.14 The reinforcement mesh is immediately embedded into the wet basecoat, and overlapping at all mesh joints should not be less than 100 mm.

8.15 Additional pieces of reinforcing mesh (250 mm by 250 mm) are used diagonally at the corners of openings as shown in Figure 5.

Figure 5 Additional reinforcement at openings

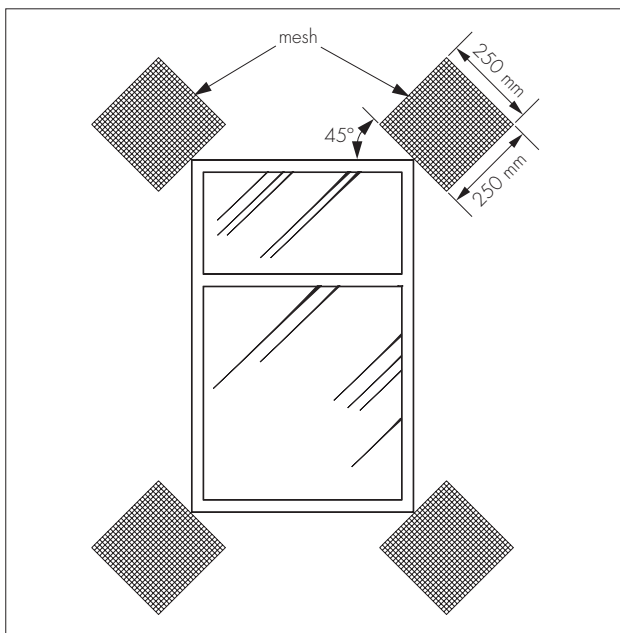

8.16 The mesh should be free of wrinkles and fully embedded in the basecoat.

8.17 Prior to the render coat, a bead of joint sealant is gun applied at window and door frames, overhanging eaves, gas and electric meter boxes, wall vents, or where the render abuts any other building material or surface.

8.18 Stop beads are positioned vertically, eg at party wall positions where the adjoining house does not require treatment.

Finishing

8.19 The basecoat should be left to dry thoroughly before application of the decorative finishes. Depending on conditions the drying time should be at least 24 hours before the top coat primer P, S_c or S_i is applied. The top coat primer is

allowed at least 2 to 6 hours before applying the Miratect R and T finish coats and 120 hours for the synthetic resin finish coats.

8.20 The finish coats are applied to the thicknesses specified in Table 2 using spray equipment or a stainless steel trowel.

Table 2 Minimum thickness of finish coat

Finish coat	Minimum thickness (mm)
Miratect R	3.0
Miratect T	2.0
Alsitect R	2.0
Alsitect T	1.5
Silitect R	1.5
Silitect T	1.5

8.21 Continuous surfaces should be completed without a break.

8.22 At the tops of walls the system should be protected by an adequate overhang (see Figure 6) or by an adequately sealed purpose-made flashing.

Figure 6 Roof eaves detail

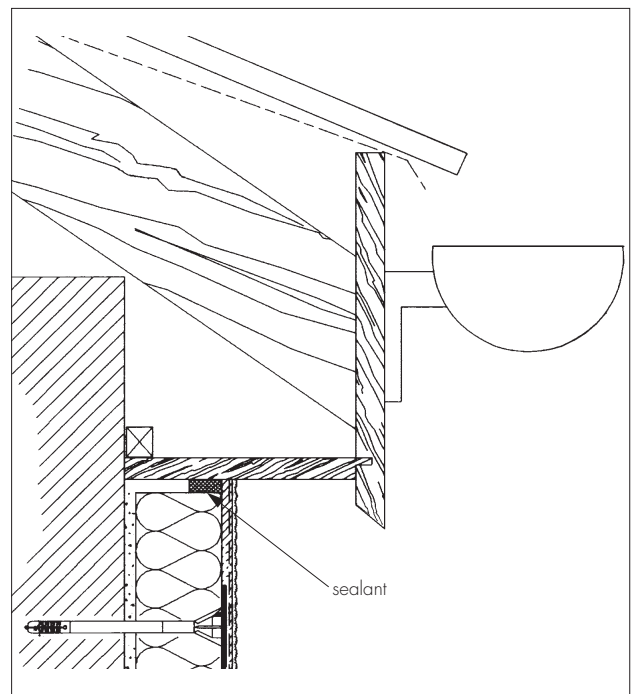

8.23 Care should be taken in the detailing of the system around openings and projections (see Figures 7, 8 and 9).

8.24 On completion of the installation, external fittings, eg rainwater goods, are securely fixed to timber grounds or extended fixings that have been built into the system during installation.

Figure 7 Insulated window detail

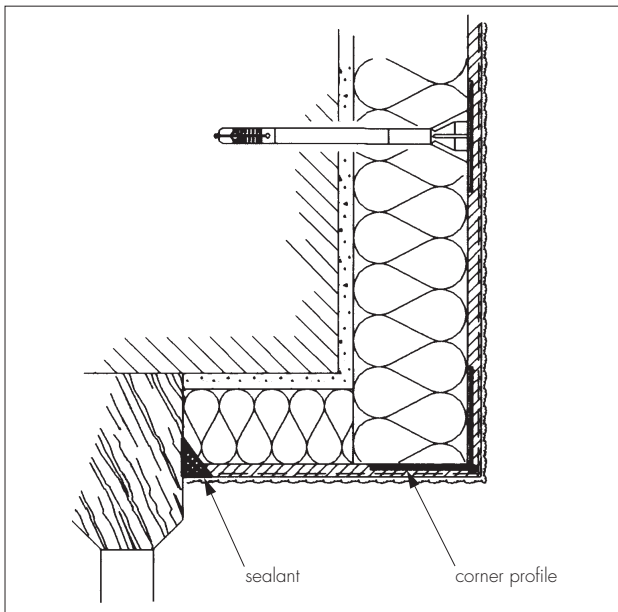

Figure 8 External corner detail

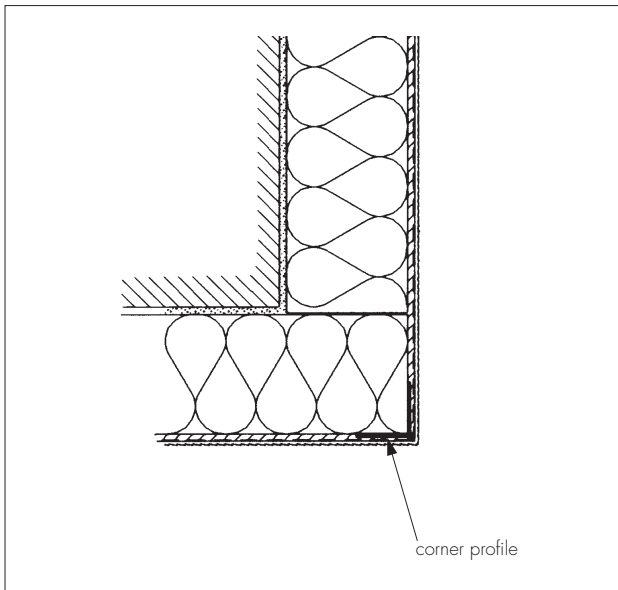
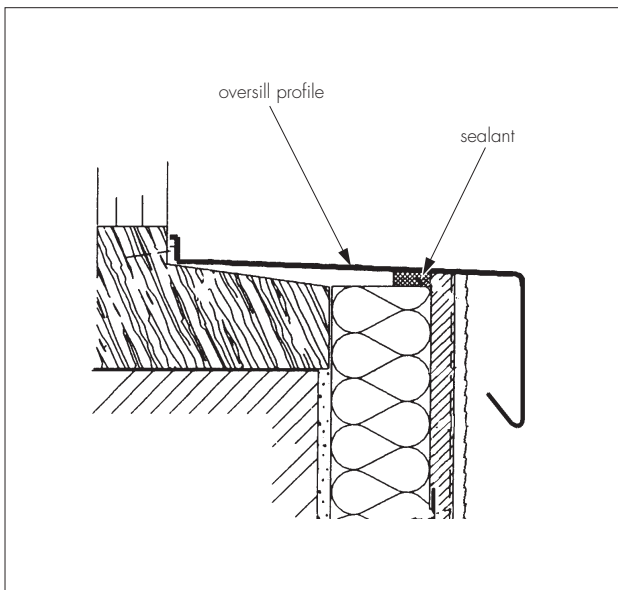

Figure 9 Window sill detail



Technical Investigations

The following is a summary of the technical investigations carried out on The Alsecco AWK2 External Wall Insulation System.

9 Tests

9.1 Tests were carried out in accordance with MOAT No 22 : 1988 to determine:

- component characterisation
- heat/spray cycling
- resistance to freeze/thaw
- impact resistance.

9.2 An examination was made of data relating to:

- water vapour permeability
- fire propagation tests to BS 476 : Part 6 : 1989
- surface spread of flame tests to BS 476 : Part 7 : 1987

- bond strength

- thermal conductivity to BS 874 : Part 2 : Section 2.1 : 1986.

10 Other investigations

10.1 The manufacturing process, the methods adopted for quality control of manufactured and bought-in components, and details of the quality and composition of the materials used, were examined.

10.2 An assessment of the risk of interstitial condensation was undertaken.

10.3 The practicability of installation and the effectiveness of detailing techniques were examined.

Bibliography

BS 12 : 1991 *Specification for Portland cement*

BS 476 *Fire tests on building materials and structures*
Part 4 : 1970(1984) *Non-combustibility test for materials*

Part 6 : 1989 *Method of test for fire propagation for products*

Part 7 : 1987 *Method for classification of the surface spread of flame of products*

BS 874 *Methods for determining thermal insulating properties*

Part 2 *Tests for thermal conductivity and related properties*

Section 2.1 : 1986 *Guarded hot-plate method*

BS 1199 and 1200 : 1976 *Specifications for building sands from natural sources*

BS 3837 *Expanded polystyrene boards*
Part 1 : 1986 *Specification for boards manufactured from expandable beads*

BS 5262 : 1991 *Code of practice for external renderings*

BS 6399 *Loading for buildings*

Part 2 : 1995 *Code of practice for wind loads*

CP 3 *Code of basic data for the design of buildings*
Chapter V *Loadings*

Part 2 : 1972 *Wind loads*

MOAT No 22 : 1988 *UEAtc Directives for the Assessment of External Insulation Systems for Walls (Expanded Polystyrene Insulation Faced with a Thin Rendering)* [supersedes MOAT No 22 : 1982]



On behalf of the British Board of Agrément

Date of issue: 20th October 1997

Director

Appendix — System summary

1 System

Adhesives	Thermastick MK and MP — cement based ready mixed adhesives supplied as a powder to which clean water is added.
Insulation	SD FRA grade expanded polystyrene boards. Nominal density of 1.5 kgm^{-3} and minimum compressive strength 70 kPa.
Reinforcement	Mesh of multi-stranded, alkali-resistant glass fibres with a polymer coating — nominal weight of 160 gm^{-2} . (Heavy duty mesh to the same specification but with a nominal density of 330 gm^{-2}).
Basecoat	Basecoat L — a cement based ready mixed basecoat supplied as a powder to which clean water is added.
Primer	Top Primer P — a plastic resin based emulsion containing fine fillers, pigment and coalescing agent used as a bonding agent and pre-coat to control suction. Top Primer Si — an acrylic resin based emulsion containing fine fillers, pigment and coalescing agent used as a bonding agent and pre-coat to control suction. Top Primer Sc — a silicon resin based emulsion containing fine fillers, pigment and coalescing agent used as a bonding agent and pre-coat to control suction.
Finishes	Miratect R — a polymer modified cement based ready mixed render supplied as a powder to which clean water is added. Alsitect R — a ready mixed, silicate based, textured coating. Silitect T — a ready mixed, silicone based, textured coating. Silitect R — a ready mixed, silicone based, textured coating. Miratect T — a polymer modified cement based ready mixed render supplied as a powder to which clean water is added. Alsitect T — a ready mixed, silicate based, textured coating.

2 Thermal properties

Thermal conductivity of insulation boards

$0.037 \text{ Wm}^{-1}\text{K}^{-1}$

U values

Using values given in Table A15 of Approved Document L1 (1995 edition) to the Building Regulations 1991 (as amended 1994) (England and Wales), the thermal insulation values for a typical 225 mm brick external wall (density 1700 kgm^{-3}) with 10 mm plasterboard:

Insulation thickness (mm)	U value ($\text{Wm}^{-2}\text{K}^{-1}$)
20	0.86
40	0.59
50	0.51
60	0.45
70	0.40
100	0.30
120	0.26

3 Impact resistance

Tests conducted by the BBA indicate that where the product may be exposed to impact, precautions should be taken to increase the resistance to possible damage (see section 3.1).

4 Properties in relation to fire

The system is classified Class 0 as defined in the appropriate Building Regulations.

5 Design wind loading and resistance to suction⁽¹⁾

Using CP 3 : Chapter V : Part 2 : 1972, the system can be designed to withstand all expected suction wind loadings.

(1) BS 6399 : Part 2 : 1985 may also be used to generate design calculations.

6 Durability

Age of oldest installation

24 years in Germany.

Assessed life

At least 30 years (with normal maintenance).